

Hexa

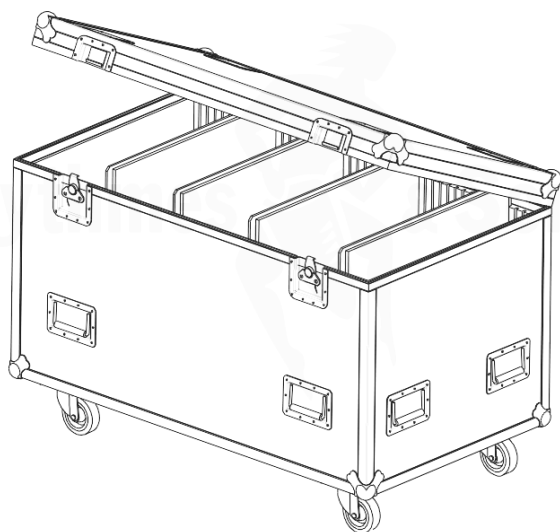

Percussion instruments / Flight cases & Hardcases for Instruments / Flight cases for Accessories

Trunk 1200x700x700 + foam padding + dividers

RYTHMES & SONS
MADE IN FRANCE

CARACTÉRISTIQUES TECHNIQUES

Référence produit	FUO 120707
Poids brut (kg)	59.00
Brand	RYTHMES & SONS (flight-cases)
Overall dimensions with wheels (mm)	1200 x 700 x H850
Interior dimensions (mm)	1100 x 620 x H600
Volume (liter)	409
Max. load	Max. 300 kg
Material	9 mm birch plywood
Finishing	Heavy-duty Hexagonal Pattern
Color	Black
Type of Opening	
Lid stays	
Type of Latches	Large recessed padlocking butterfly latch with guided opening/closing mechanism

TRUNK 1200X700X700 WITH PADDING FOAM AND 4 MOVABLE DIVIDERS WITH FOAM PADDING

Product specifications and fittings

- > Trunk-style configuration
- > Hinged top lid
- > Heavy-duty 9 mm birch plywood with Black Hexagonal Pattern
- > 2 large recessed butterfly latches with guided opening/closing mechanism 1 with padlock brackets
- > 2 lid stays in dish on the back
- > 8 recessed flip handles with double sprung
- > 4 swivel castors Ø100 (2 with brake)
- > 4 recessed dishes for stacking

Interior features

- > Foam padding
- > Grooved foam On the large sides
- > 4 Movable dividers with foam padding

Number of Latche(s)	2
Type of Handle	
Number of Handle(s)	8
Dish for stacking	Yes
Stackable	
Castors	2+2 with brakes Ø100