

Flight cases / Video & computer flight cases / Flight cases for videoprojectors

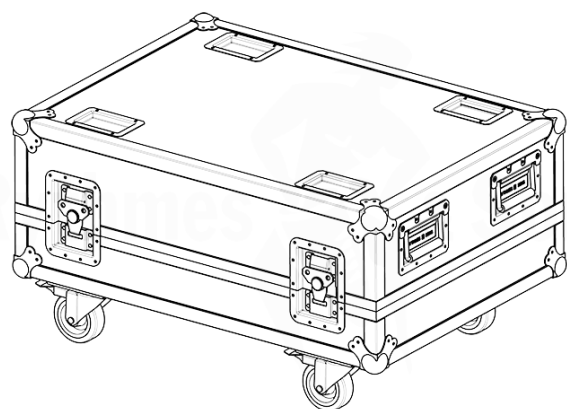

Flight case for videoprojector PANASONIC PT-RZ670 Series



CARACTÉRISTIQUES TECHNIQUES

Référence produit	FVP PA 505820
Poids net (kg)	32.00
Brand	RYTHMES & SONS (flight-cases)
Packaged product	PT-⁠RW630, PT-⁠RZ670
Overall dimensions with wheels (mm)	820x690xH470

FLIGHT CASE FOR PROJECTORS PANASONIC PT-RZ670 SERIES + LAMP + ACCESSORIES

Product specifications and fittings

- > Top opening with shallow base
- > 9 mm BROWN phenolic faced birch plywood
- > 4 large recessed butterfly latches with guided opening/closing mechanism
- > 4 recessed flip handles with double sprung
- > 4 swivel castors Ø100 (2 with brake)
- > 4 recessed dishes for stacking

Interior features

- > Foam cushioning for projector without lens
- > Compartments on the side with removable dividers and foam padding for lenses and accessories.

Developed and manufactured by Rythmes & Sons in France