

Flight cases / Events / Video & computer / Cases for Broadcast panel

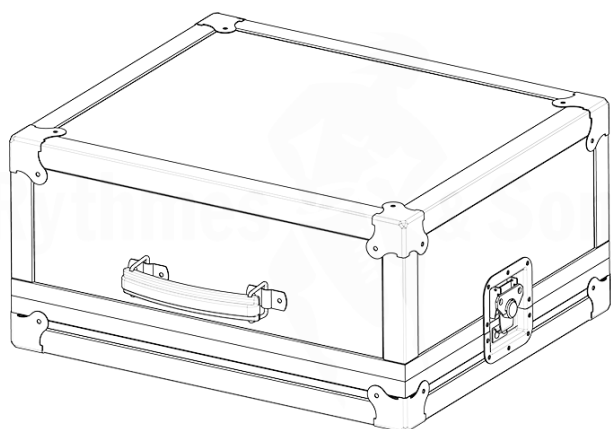

PANASONIC **AV-HS410**
Flight case for 1 live switcher



CARACTÉRISTIQUES TECHNIQUES

Référence produit	FVM PA AV-HS410
Poids net (kg)	10.20
Brand	RYTHMES & SONS (flight-cases)
Overall dimensions with wheels (mm)	520x440xH225

FLIGHT-CASE FOR 1 AV-HS410 PANASONIC LIVE SWITCHER

Product specifications and fittings

- > Top opening with shallow base
- > Heavy-duty 9 mm birch plywood with black Hexagonal Pattern
- > 2 small recessed butterfly latches
- > 1 leather handle

Interior features

- > Foam cushioning

Developed and manufactured by Rythmes & Sons in France